

OPERATION

Valve blocks between 2 and 3 until sufficient pilot pressure is applied at 1 to open the valve. Note that pressure at 2 is additive to the spring setting.

SPECIFICATIONS

Theoretical performance

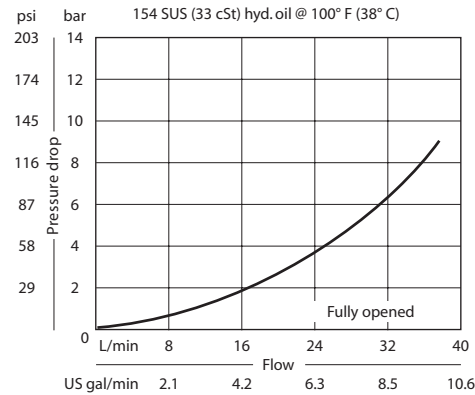

Schematic

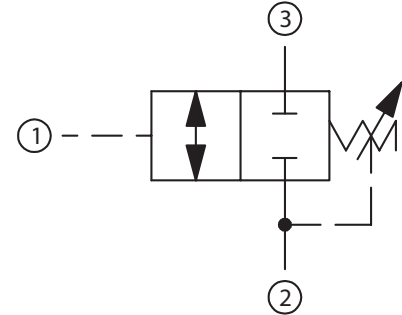

Specifications

Rated pressure	210 bar [3000 psi]
Rated flow at 7 bar [100 psi]	35 l/min [9 US gal/min]
Weight	0.24 kg [0.52 lb]
Cavity	SDC10-3

DIMENSIONS

mm [in]

Cross-sectional view

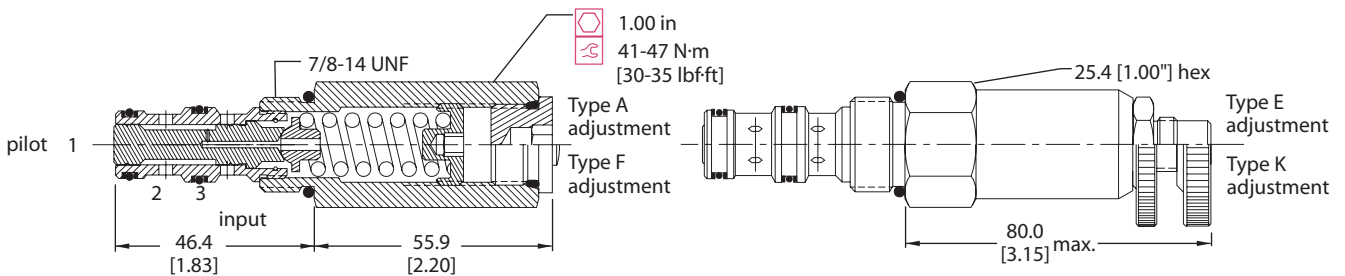

ORDERING INFORMATION

CP240 - 2 - B - 6S - A - C - 100

Seals
 B = Buna-N
 V = Viton

Housing and ports
 0 = No Housing
 SE3B = Al, 3/8 BSP
 SE4B = Al, 1/2 BSP
 6S = Al, #6 SAE
 8S = Al, #8 SAE
 Other housings available

Adjustment option
 A = Internal
 E = External
 F = Tamper resistant
 K = Knob

Seal kit
 120009
 120010

Housing P/N
 No Housing
 SDC10-3-SE-3B
 SDC10-3-SE-4B
 CP10-3-6S
 CP10-3-8S

Crack pressure
 Code x 10 = psi
 Example: 100 = 1000 psi

Pressure range

	bar	[psi]
A =	4-28	[50-400]
Std. setting	17	[250]
B =	5-55	[75-800]
Std. setting	28	[400]
C =	7-97	[100-1400]
Std. setting	69	[1000]
D =	34-166	[500-2400]
Std. setting	103	[1500]