

OPERATION

This is a normally open, pilot-operated, poppet-type 16-size solenoid valve. When de-energized, the HSVP16-NO severely restricts flow from port 1 to port 2, while blocking flow from port 2 to 1. When energized, the valve's poppet is shifted to block flow from port 2 to port 1, and allow reverse flow between port 1 to port 2 at a high pressure drop.

This valve comes standard with a push pin type manual override.

APPLICATIONS

This valve is designed for use for uni-directional blocking, load holding, clamping or gripping applications in hydraulic circuits where low internal leakage is required.



Shown with Standard H16 Coil, Deutsch Connector

SPECIFICATIONS

Rated pressure*	350 bar [5075 psi]*
Rated flow at 7 bar [100 psi]	152 l/min [40 US gal/min]
Leakage	6 drops/min @ Rated pressure
Weight	0.73 kg [1.61 lb]
Cavity	SDC16-2
Standard Coil	H16 29 Watt

* Rated Pressure based on NFPA fatigue test standards (at 1 Million Cycles).

SCHEMATIC

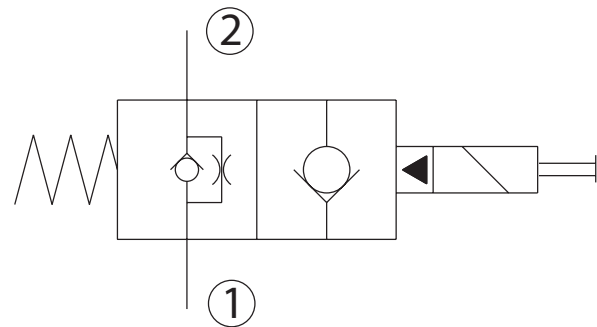

PERFORMANCE CURVES

Pressure Drop
 26 cSt [121 SUS] hyd.oil at 50°C [122 °F]

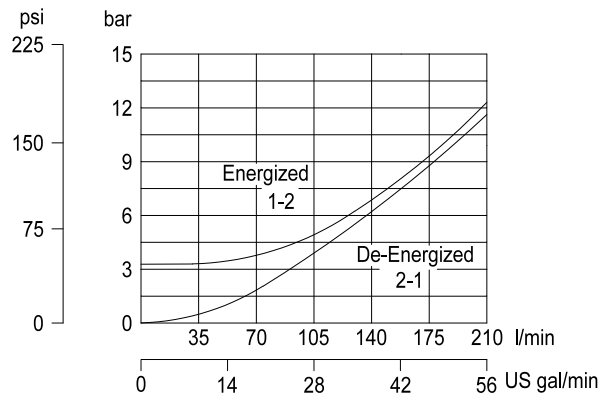

DIMENSIONS

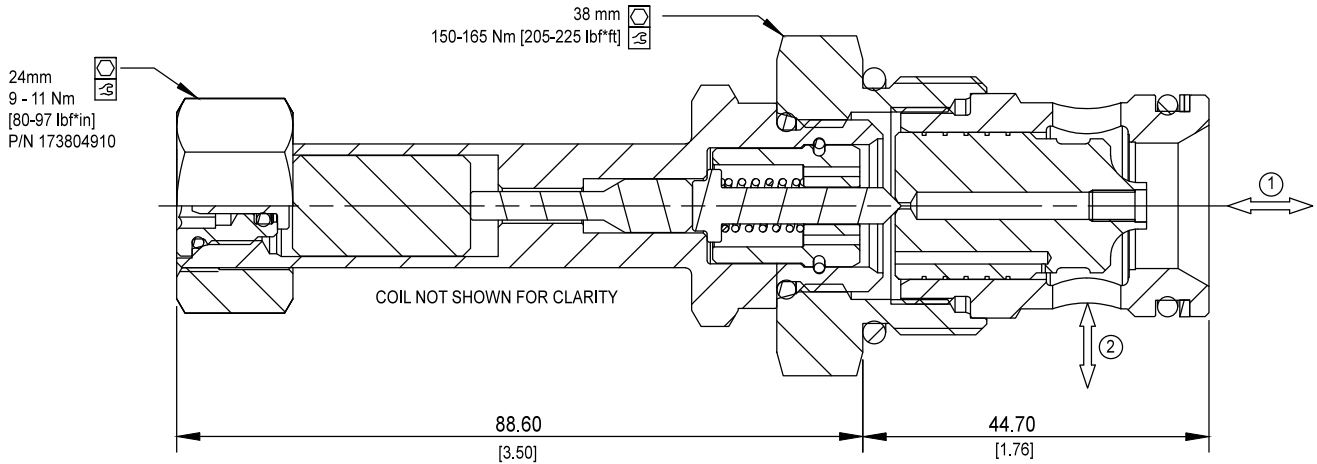

EXAMPLE CIRCUITS

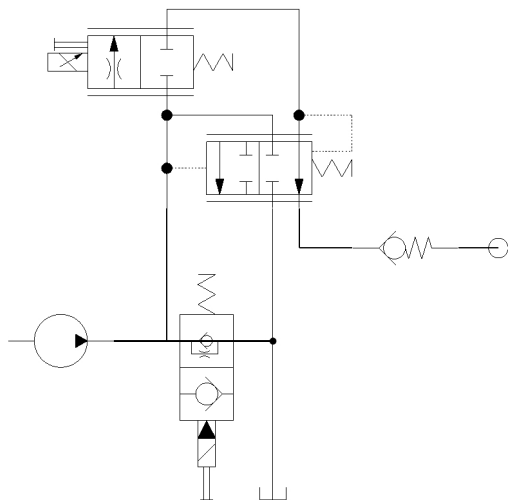

Pump unloading

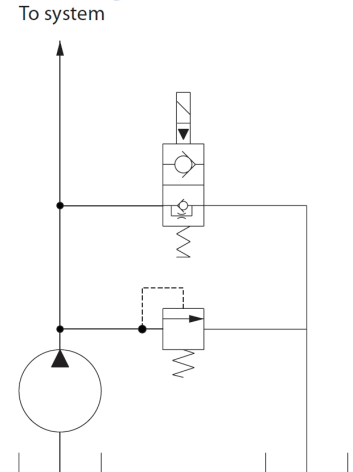

SV - Solenoid Valves
 HSVP16-NO

ORDERING INFORMATION

HSVP16 - NO - H12D - DE - PN - B - 00

High Pressure Solenoid Valve
 Normally-Open, Pilot Operated,
 16 Size, Poppet Type

Coil Voltage

Code	Description
H00	No Coil
H12D	12 VDC
H24D	24 VDC

Coil Termination

Code	Description	IP Rating
00	No Coil	-
FL	Flying Lead	IP69K
DE	Deutsch	IP69K
AS	AMP Super Seal 1.5 & Metri Pack 150 type 1	IP69K
ASDB	AMP Super Seal with Diode Bidirectional	IP69K
DEDB	Deutsch with Diode Bidirectional	IP69K
FLDB	Flying Lead with Diode Bidirectional	IP69K

Bodies

Code	Ports & Material	Body Nomenclature
00	Cartridge Only	No Body
12S	#12 SAE, AL	SDC16-2-12S
S12S	#12 SAE, DUCTILE	SDC16-2-S12S
16S	#16 SAE, AL	SDC16-2-16S
S16S	#16 SAE, DUCTILE	SDC16-2-S16S
6B	3/4 BSP, AL	SDC16-2-6B
S6B	3/4 BSP, DUCTILE	SDC16-2-S6B
8B	1 BSP, AL	SDC16-2-8B
S8B	1 BSP, DUCTILE	SDC16-2-S8B

**Aluminum bodies are to be used for lower pressures less than 210 bar (3,000 psi)

Seal Option

Code	Seal Material	Seal Kit
B	Buna	120019
V	Viton	120020

Manual Overrides

Code	Description
PN	Push Pin
OPS	Push Pin M/O Nut for Protection & Actuation
PAT	Push and Twist